

Specifications

Output Power HP (kW)	15 (11)
Phase	3 Phase
Pole	6 Pole
Frame Number	160L

Degrees of Protection	IP 55
Enclosure Construction	Totally-enclosed Fan-cooled
Thermal Class	Class F (155 °C)

Alignment	Horizontal
Frame Material	Cast Iron

Power Transmission	Direct-couple or Belt Driven
Direction of Rotation	Counterclockwise (CCW) viewed from shaft-end side



Connection Type	Lead Wire (6 Leads)
Coating Colour	Munsell N5.5 (Gray)
Conformed Standard	IEC 60034-1 & JEC-2137-2000



Voltage & Frequency	HT Type
	380~415V 50Hz
	380~440V 60Hz (suitable for γ - Δ starting)

* The perpendicular variation of tolerance for the shaft center is $\begin{matrix} 0 \\ -0.5 \end{matrix}$

Dimensions (mm)

Motor												
A	B	C*	D	E	F	G	H	I	J	JK	L	M
274	229	160	324	127	127	20	322	373	55	R6	619	310

Motor		Terminal Box			Shaft End							
N	XB	Z	KG	KD	KL	Q	QK	R	S	T	U	W
304	108	15	127	PF 1 1/4	271	110	90	345	42 k6	8	5	12

Bearing No.		Approximated Weight (kg)	Approximated Packing Dimensions (LxWxH)	Gross Weight (kg)
Drive End	Opposite			
6309ZZ	6308ZZ	135	787 x 601 x 494	156

Connection & Connection Diagram

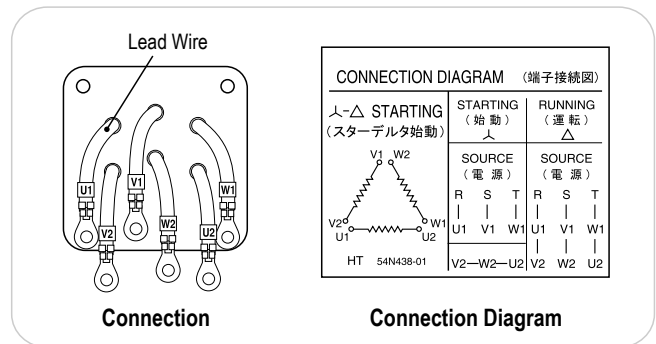

Circumstance Conditions

Ambient Temperature	-20 ~ +40°C
Ambient Humidity	95% RH or less
Operating Altitude	Less than 1,000m above sea level
Environment	No bursting / erosive gas or vapor

Motor Characteristics

Type	Hz	V	50% Load			75% Load			100% Load				Torque(%)		Is (A)	Inertia GD ² (kg-m ²)	
			(A)	Eff(%)	PF(%)	(A)	Eff(%)	PF(%)	(A)	Eff(%)	PF(%)	Speed (r/min)	Torque (kg-m)	Ts			Tm
HT	50	380	14.3	0.89	0.66	18.4	0.90	0.76	23.3	0.90	0.80	960	11.2	218	204	125	0.51
		415	15.8	0.86	0.56	19.2	0.88	0.68	23.0	0.89	0.75	970	11.0	260	243	137	
	60	380	12.6	0.88	0.75	17.0	0.90	0.82	22.2	0.90	0.84	1140	9.4	183	185	109	
		440	12.9	0.89	0.63	16.2	0.90	0.74	20.1	0.91	0.79	1160	9.2	241	248	127	